

Goldilocks Patterns



Setting: Small Group

Objective: Identify, create, and extend patterns

Materials Needed:

- One pattern mat per child in your small group
- Copies of the patterning pieces
- Optional- you can place small Velcro dots on the back of the patterning pieces and the blank squares to keep them from sliding off the mat.
- Additional- you can use other materials such as stickers or stamps to make patterns on the blank mats.

Directions:

Print, laminate, and cut out the pattern pieces on pages 30-33. Print and laminate the pattern mats on pages 27-29. Give one pattern mat to each child in your small group. Place the patterning pieces in a basket or other container in the middle of the table so all students can easily access them. Students will identify and extend the patterns on their mats. A blank mat is also included for those students who are ready to create their own patterns. To support oral language and vocabulary development ask the students to “read” you their patterns by identifying the items in each row. I have also included three pattern worksheets on pages 35-37 for more advanced students or assessment purposes.

Graphics licensed from [Scrappin Doodles](#)

I Can Make an AB Pattern!

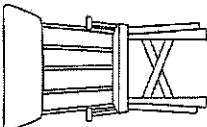
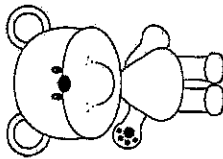
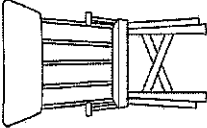
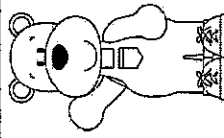
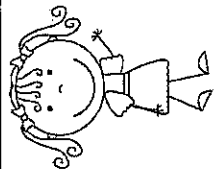
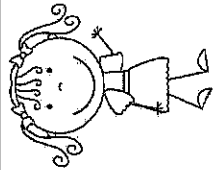
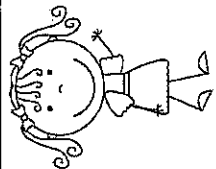
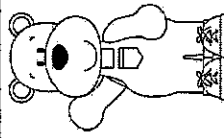
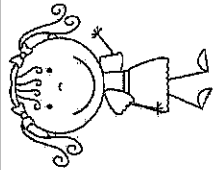
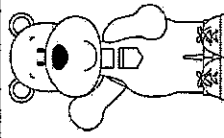
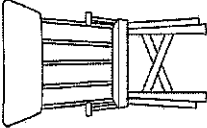
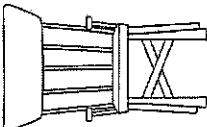

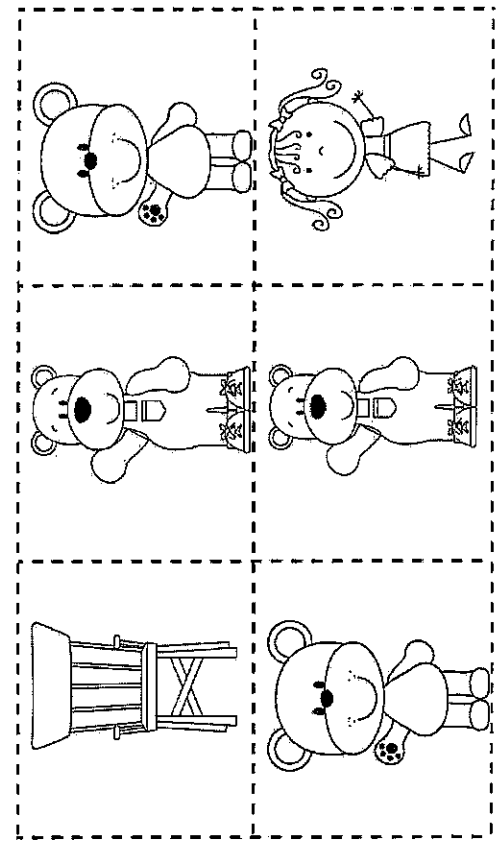
I Can Make an AABB Pattern!

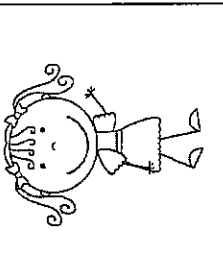
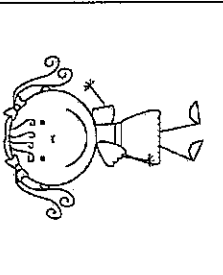
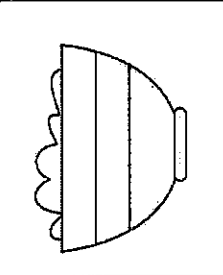
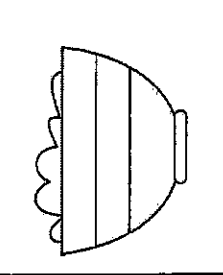
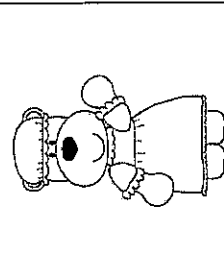
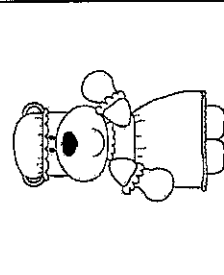
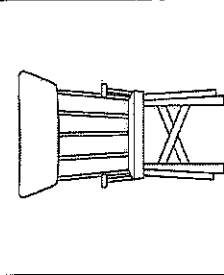
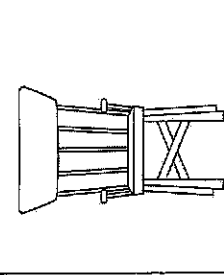

I Can Make an ABC Pattern!

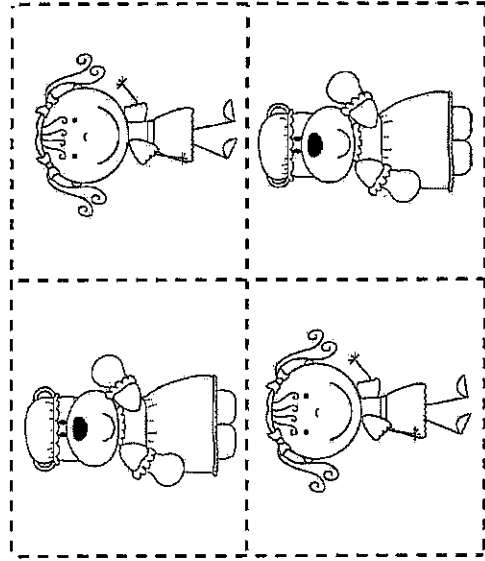