

Goldilocks Story Sequencing

Setting: Small or Large Group

Objective: Identify beginning, middle, and end of a story. Also supports Common Core Kindergarten Standard: RL.K.2. With prompting and support, retell familiar stories, including key details.

Materials Needed:

- Printable Story Sequence Sheet, one per child
- Scissors
- Glue Stick
- Construction Paper
- Crayons

Directions:

Print one story sequence sheet for each child in your small group. There are two different story sequence sheets included so you can choose the one that best meets the needs of your students. In my experience, most young children are not ready for 4 part story sequence activities until they are 4.5 years of age or older. Students can color and cut the pictures out, then glue in order from left to right on a strip of construction paper. There is also a strip that you can copy and pre-cut to glue at top of the story sequence papers. This strip reads, "I can retell the story of Goldilocks and the Three Bears. Ask me to tell you about it."

Graphics for Goldilocks Story Sequence created by [ScrappinDoodles](http://ScrappinDoodles.com)

Goldilocks 3 Part Story Sequence

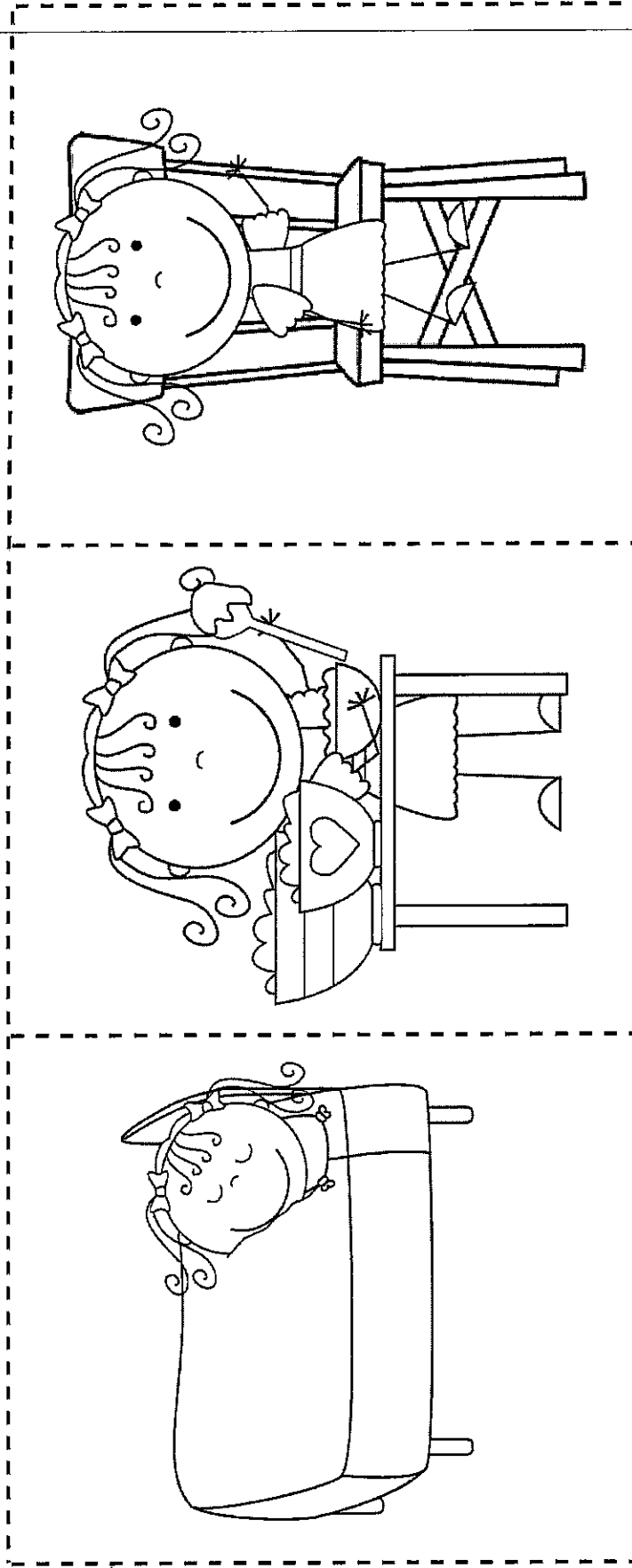

Goldilocks 4 Part Story Sequence

